

# HEAVY DUTY FLOODED BATTERY

115F51L (12V120Ah)



## CHARACTERISTICS

Item	Specifications	
Nominal Voltage	12V	
Nominal Capacity (20HR)	120Ah	
Reserve Capacity	223min	
Cold Cranking Amps@0°F (-18°C)	800A	
Dimension	Length	504mm (19.8inches)
	Width	183.5mm (7.22inches)
	Height	223mm (8.78inches)
Approx Weight	32.9kg (72.5lbs)	
Terminal	1	
Cell layout	4	
Hold-Down	B0	
Case	Black-PP Material	
Cover	Black-PP Material	
Handle	TS8	

## APPLICATIONS

- Commercial vehicle start
- Engine start

## GENERAL FEATURES

- High capacity and high CCA
- Maintenance-free
- High vibration resistance
- Strong lead-calcium alloy grids for great corrosion resistance
- High strength PP case and cover no need be worried about breakage
- OE quality certification

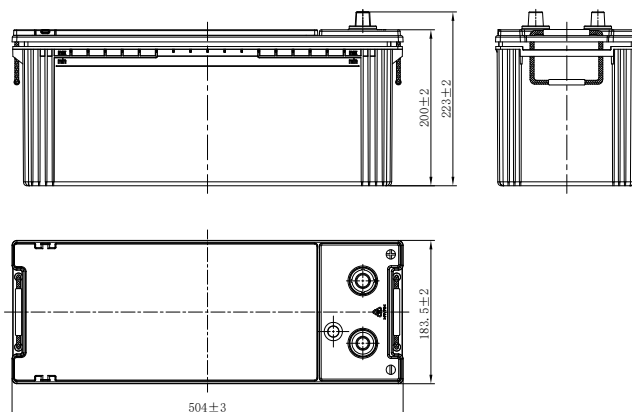
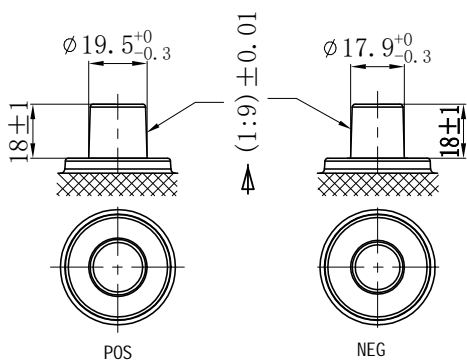

\*Values are subject to variation of +/- 5% in normal manufacturing processes.

Leoch International Technology Ltd.  
 www.leoch.com

Leoch Batteries Pte Ltd  
 www.leoch.sg

Leoch Battery Corporation  
 www.leochamericas.com

Leoch Europe S.A.  
 www.leoch.eu